

# ACOPLAMIENTOS ELASTICOS

Tipo de construcción: A = dos partes

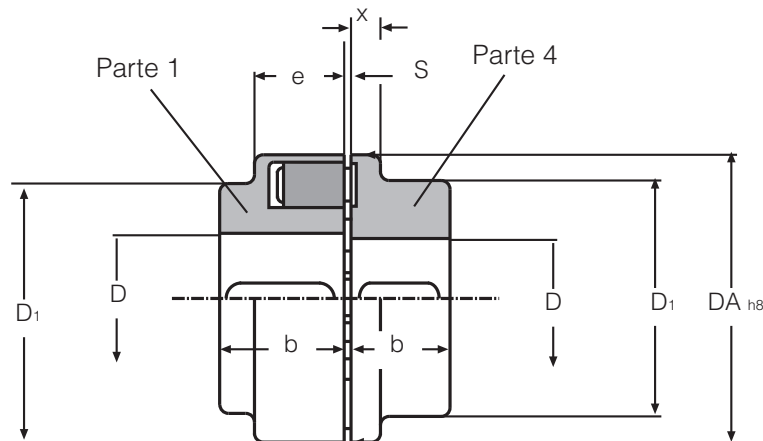

Tipo de construcción A

Acoplamiento elástico	máx. rev. 1/min	Momento de torsión nominal Nm	Valor nominal $\frac{p_n(kw)}{n}$	Perforación D		Momento de inercia $kgm^2$	Peso en kg	Cant. tacos	Dimensiones mm						
				Parte 1 de a	Parte 4 de a				D <sub>1</sub> D <sub>A</sub>	Parte 1	Parte 4 x	b	e	s	
EK 58 A	5000	19	0,002	8 - 19	8 - 24	0,0002	4	0,45	58	58	40	8	20	20	2-4
EK 68 A	5000	34	0,0036	8 - 24	8 - 28	0,0003	5	0,63	68	68	46	8	20	20	2-4
EK 80 A	5000	60	0,0063	10 - 30	10 - 38	0,0012	6	1,50	80	80	68	10	30	30	2-4
EK 95 A	5000	100	0,011	11 - 42	11 - 42	0,0027	6	2,60	95	76	76	12	35	30	2-4
EK 110 A	5000	160	0,017	14 - 48	14 - 48	0,0055	6	4,00	110	86	86	14	40	34	2-4
EK 125 A	5000	240	0,025	16 - 55	16 - 55	0,0107	6	6,10	125	100	100	18	50	36	2-4
EK 140 A	4900	360	0,038	18 - 60	18 - 60	0,0140	6	7,00	140	100	100	20	55	34	2-4
EK 160 A	4250	560	0,059	22 - 65	22 - 65	0,0250	7	9,40	160	108	108	20	60	39	2-6
EK 180 A	3800	880	0,092	24 - 75	24 - 75	0,0450	8	14,00	180	125	125	20	70	42	2-6
EK 200 A	3400	1340	0,14	28 - 85	28 - 85	0,0800	8	20,00	200	140	140	24	80	47	2-6
EK 225 A	3000	2000	0,21	38 - 90	38 - 90	0,1350	8	24,00	225	150	150	18	90	52	2-6
EK 250 A	2750	2800	0,29	48 - 100	48 - 100	0,2300	8	34,00	250	165	165	18	100	60	3-8
EK 280 A	2450	3900	0,41	55 - 110	55 - 110	0,3700	8	45,00	280	180	180	20	110	65	3-8

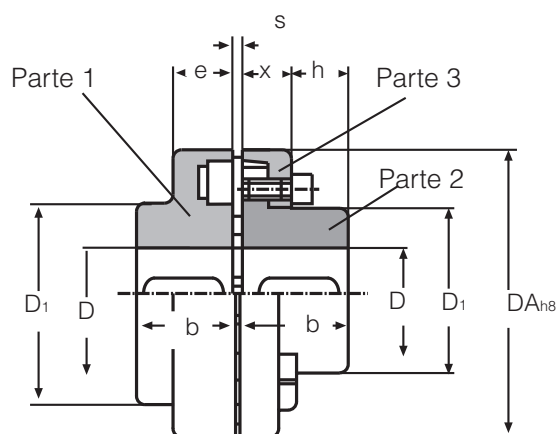

Tipo de construcción B

Acoplamiento elástico	máx. rev. 1/min	Momento de torsión nominal Nm	Valor nominal $\frac{p_{n(kw)}}{n}$	Perforación D		Momento de inercia $\text{kgm}^2$	Peso en kg	Cant. tacos	Dimensiones mm							
				Parte 1 de a	Parte 4 de a				$D_A$	Parte 1	Parte 4 x	b	e	h	s	
EK 110 B	5000	160	0,017	14 - 48	14 - 38	0,0047	6	3,5	110	86	62	20	40	34	33	2-4
EK 125 B	5000	240	0,025	16 - 55	16 - 45	0,0095	6	5,6	125	100	75	23	50	36	38	2-4
EK 140 B	4900	360	0,038	18 - 60	18 - 50	0,0150	6	7,0	140	100	82	28	55	34	43	2-4
EK 160 B	4250	560	0,059	22 - 65	22 - 58	0,0280	7	9,8	160	108	95	28	60	39	47	2-6
EK 180 B	3800	880	0,092	24 - 75	24 - 65	0,0490	8	14,2	180	125	108	30	70	42	50	2-6
EK 200 B	3400	1340	0,14	28 - 85	28 - 75	0,0850	8	19,8	200	140	122	32	80	47	53	2-6
EK 225 B	3000	2000	0,21	38 - 90	24 - 85	0,1500	8	27,0	225	150	138	38	90	52	61	2-6
EK 250 B	2750	2800	0,29	48 - 100	32 - 95	0,2500	8	37,0	250	165	155	42	100	60	69	3-8
EK 280 B	2450	3900	0,41	55 - 110	55 - 105	0,4000	8	48,0	280	180	172	42	110	65	73	3-8
EK 315 B	2150	5500	0,58	100 - 120	100 - 120	0,7100	9	66,0	315	200	195	47	125	70	78	3-8
EK 350 B	1950	7700	0,81	65 - 110	65 - 110	1,1000	9	86,0	350	180	180	51	140	74	83	3-8
EK 400 B	1700	10300	1,10	70 - 120	70 - 120	1,9000	10	122,0	400	200	200	56	160	78	88	3-8
EK 440 B	1550	13500	1,40	80 - 130	80 - 130	3,0000	10	159,0	440	215	215	64	180	86	99	5-10
EK 480 B	1400	16600	1,70	90 - 145	90 - 145	4,6000	10	200,0	480	240	240	65	190	90	104	5-10